

MULTI-POINT INSPECTION - OUTBOARD MOTOR

The Yamaha multi-point inspection is a series of visual checks performed by your dealer. In the event that service is recommended on a listed item, your Yamaha service advisor will be happy to speak with you about the available options.

This report is an inspection only. Be sure to follow the routine maintenance schedule outlined in your outboard owner's manual.



Customer Name	Date	RO/Tag
Hours of Use	Year/Model	Product ID
		Hull Identification Number

OKAY AT THIS TIME	REQUIRES ATTENTION SOON	REQUIRES IMMEDIATE ATTENTION	NOT CHECKED / NOT APPLICABLE
--------------------------	--------------------------------	-------------------------------------	-------------------------------------

FACTORY MODIFICATION CAMPAIGN REQUIRED	YES <input type="checkbox"/>	NO <input type="checkbox"/>
---	------------------------------	-----------------------------

YDIS DOWNLOAD REPORT ATTACHED	YES <input type="checkbox"/>	NO <input type="checkbox"/>
--------------------------------------	------------------------------	-----------------------------

GENERAL INSPECTIONS

Engine Mounting				
Engine Hood, Seal, Latch				
Lower Unit / Skeg Condition				
Propeller Condition				
Anode(s) Condition				

FLUIDS AND FUEL SYSTEM

Engine Oil: Level / Leaks				
Lower Unit: Fluid Level / Leaks				
Power Steering: Fluid Level / Leaks				
Power Tilt/Trim: Leaks				
Fuel Tank, Fuel Lines, Connections				
Standard Water Separator & Fuel Filter				
Optional 10 Micron Water Separator & Fuel Filter				

MECHANICAL

Engine Pull Cord				
Pilot Water Outlet				
Idle and Trolling Speed				
Throttle and Shifting Controls				
Steering System				
Engine Tilt System				

ELECTRICAL

Battery Mounting, Battery Switch, Cables, and Connections				
Engine Start/Stop and Lanyard Operation				
Power Trim/Tilt: Switch and Motor Operation				

BATTERY LOAD TEST

Battery One: Checked with size-appropriate tester				
Battery two: Checked with size-appropriate tester				

SERVICE TECH: <input style="width: 80%;" type="text"/>
NEXT SERVICE: DUE NOW <input style="width: 20%;" type="checkbox"/> DUE AT <input style="width: 40%;" type="text"/> HRS/KMS <input style="width: 20%;" type="text"/>

INDICATE AREAS OF EXTERNAL DAMAGE OR WEAR

Unit photos saved to file

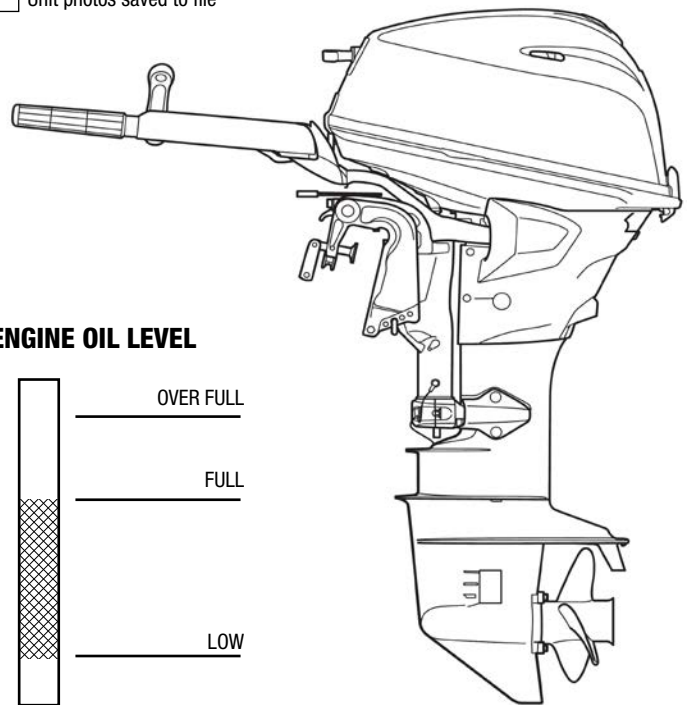

COMMENTS

Customer Signature _____

Talk to your dealer today about Yamalube and Genuine Yamaha Parts and Accessories or browse online // YAMAHA-MOTOR.CA